



OWNER'S SUPPLEMENT

SAHARA
SERENGETI
IVORY

Safari Motor Coaches
30725 Diamond Hill Rd.
Harrisburg, OR 97446
Service 1-800-344-6332

Revision Date: 10-10 - 1995

The descriptions and specifications in this manual were in effect at the time of its approval for printing. The manufacturer reserves the right to change specifications or designs without notice and without incurring obligation.

Table Of Contents

| | |
|------------------------------------|-----------|
| <i>Electrical System</i> | <i>1</i> |
| <i>Chassis and Dash</i> | <i>13</i> |
| <i>Locator Guide and Reference</i> | <i>25</i> |

CHAPTER ONE

ELECTRICAL SYSTEM

OVERVIEW

The electrical system in your Safari motor coach is designed to provide maximum flexibility and power with a minimum of fuss. Our engineers have produced a system through which a complex web of circuitry can operate virtually automatically, responding to your demands in the optimum manner. There are mechanisms to prevent such problems as battery drain, and numerous safety features. The system is so auto-

ELECTRICAL SYSTEM

matic that you might be tempted to skip this part of the manual, but you will gain even more from a thorough understanding of this material.

The electrical system can be divided into two connected parts, the 120VAC and the 12VDC systems. 120VAC is the same type of electrical power which is found in homes. It provides substantial power for appliances and lighting. Examples in your coach of 120VAC appliances include the television, microwave oven, and "residential" lighting, as well as the three-pronged outlets scattered through the coach. 12VDC is suitable for low-power applications, such as small lights, fans, indicators, and appliances. The chassis uses 12VDC power to start the engine and to run the dash and lights.

The two systems are connected by an inverter, which transforms 12VDC power into 120VAC, and a converter, which

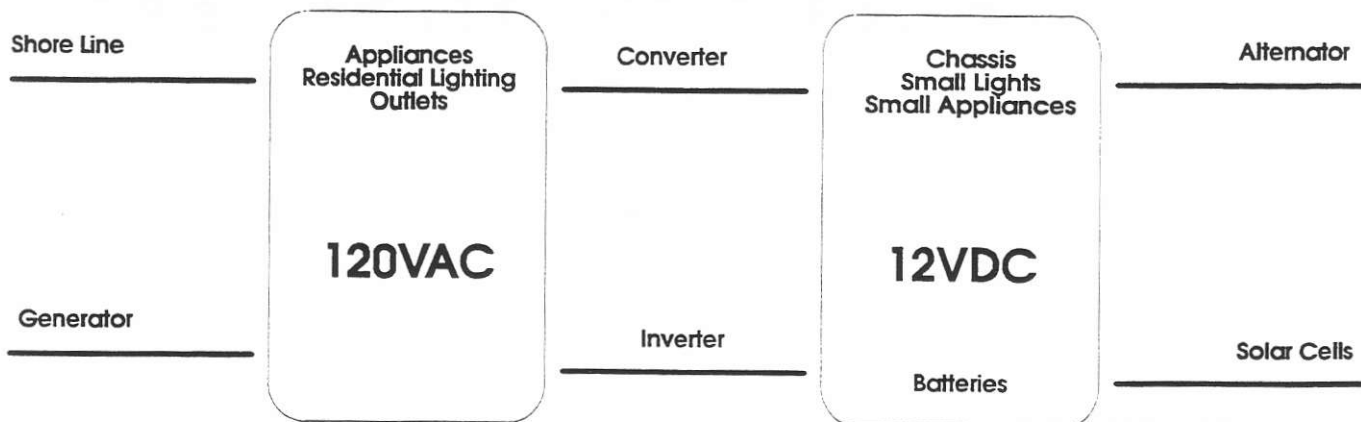

Electrical System (Simplified)

does the opposite. These devices are fully explained later in this chapter.

Your coach can draw on several sources of power. 120VAC power can be supplied by a "shore line" connection at your house or park site. It can also be produced by your generator. 12VDC power is generated by the alternator in your engine, and by the solar panels. Power is stored in two sets of batteries.

A simplified drawing illustrates the general layout of your system. More detailed drawings follow later in the chapter.

WARNING: Modifying the circuitry in your motor home may void the warranties of the coach and any appliances on that circuit.

WARNING: Whenever working with circuitry, always follow strict safety precautions. Never work on a live circuit. Always use proper tools and techniques. Never bypass breakers or fuses.

120VAC SYSTEM

The 120VAC system provides the same 60 hertz standard power found in all North American homes. Virtually any appliance you can run at home on a standard outlet you can use in your Safari, within the overall amperage limitations. The system is protected from overloads by a set of circuit breakers located on a single panel.

The system can take power from any of three sources: generator, shore line, or inverter. Power is drawn from the most appropriate source automatically.

ELECTRICAL SYSTEM

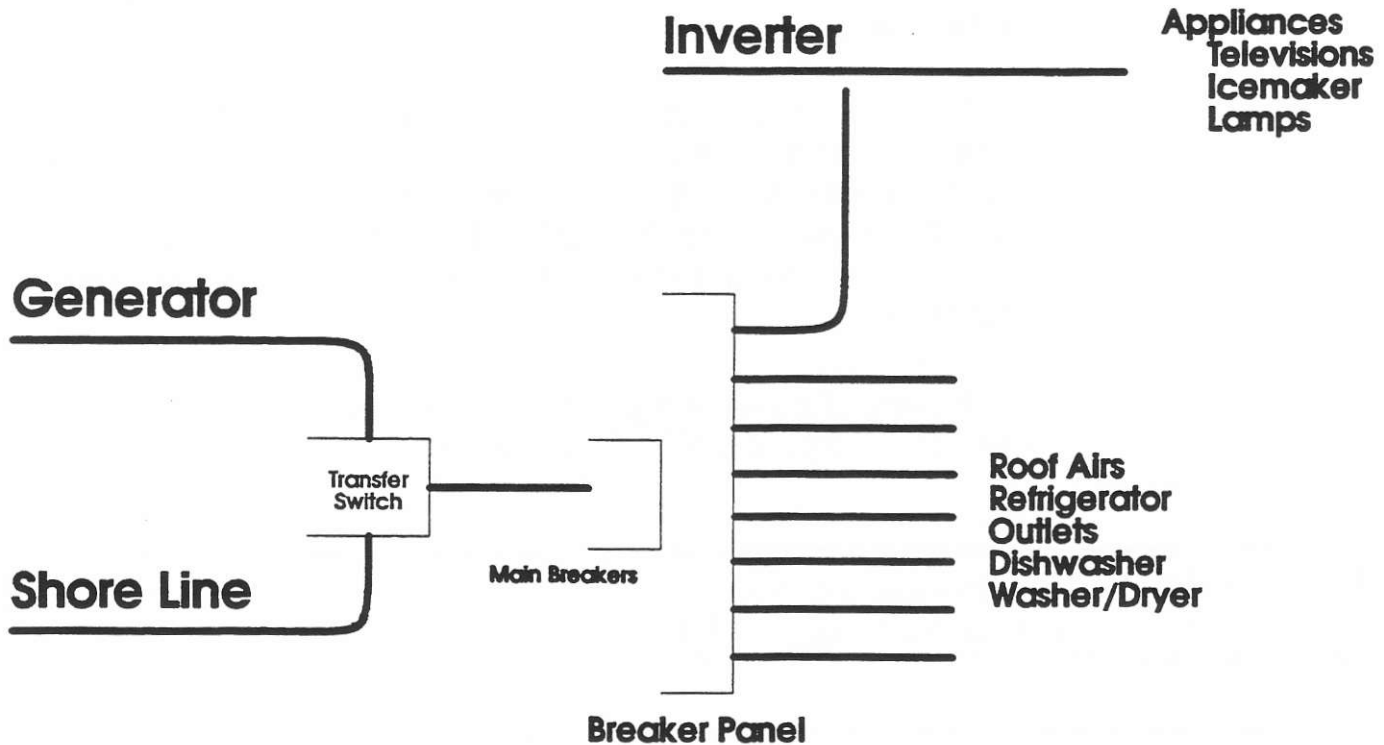

120VAC System

CIRCUIT BREAKERS AND G.F.C.I.

The 120VAC system has two important safety mechanisms. First, a set of circuit breakers prevents any circuit from being overloaded. An overload can result from a short circuit, a faulty appliance, or too many appliances being run on the same circuit. The system is divided into several separate circuits, which decreases the load on each circuit and allows other circuits to operate if one circuit goes down.

WARNING: Never attempt to bypass the circuit breakers for any reason. Doing so will void the warranty both of your coach and any appliances on the circuit. Furthermore, a circuit without a breaker presents a serious safety hazard.

The breaker panel is labeled with the appliances and outlets on each circuit. In addition to the 20 amp circuit breaker for each of the eight circuits, there are two large 50 amp main breakers which protect the full system. If an appliance or outlet is not receiving power, check both the main breakers and the breaker for that outlet's circuit.

Note that the inverter contains its own circuit breaker, and power from it is not channeled through the main panel. If the inverter is not producing power, check the breaker on the inverter itself.

G.F.C.I. refers to Ground Fault Circuit Interrupt. This is a safety feature which halts power through a circuit if a short or other malfunction is detected. This is an important mechanism, designed to help prevent electrocution injuries. The G.F.C.I. works in a manner similar to a circuit breaker. If a fault is detected in the circuit, a switch inside the G.F.C.I. is tripped, halting power flow. The circuit will not operate again until the switch is reset on the G.F.C.I. receptacle.

There are two G.F.C.I. receptacles in your coach. The first is the bathroom outlet, which also protects the galley and patio outlets. The second is at the inverter and protects the entire inverter circuit if no other power source is available. If power is not available on any of these circuits, check the G.F.C.I. outlet and reset the switch, if necessary, by pressing the red button in fully.

GENERATOR AND SHORE LINE

The generator runs on LP Gas, and provides a very efficient source of 120VAC power. For full specifications, instructions, and maintenance requirements on the generator, please refer to the manual in the warranty pack. This manual contains only an overview - it is not a substitute for the manufacturer's documentation.

ELECTRICAL SYSTEM

You can start your generator using the remote switch on the monitor panel. Simply press the "start" button and hold it until the generator starts. To stop the generator, press the "stop" button until it comes to a complete halt.

If the generator does not start promptly, let off the button and try again. Continuous cranking can damage the generator starter.

Do not neglect the maintenance of the generator. A full schedule is provided in the generator manual, and an hourmeter is mounted on the monitor panel by the start/stop button. If you are operating it in dirty or dusty conditions you should accelerate the schedule accordingly. Monitor the generator for signs of problems, such as odd noises, power loss, and overheating. If any such signs appear, have the generator serviced promptly.

WARNING: Never use your generator as an emergency power source for a residence. Plugging the house into a coach may allow electricity to flow back to the utility lines. This would present an extreme hazard to any technician working to restore power.

WARNING: Never store anything in the generator compartment. Using this area for storage presents a fire hazard, and may prevent the correct operation of the generator.

Your coach is provided with a 25 foot shore line. To utilize the power available from a house or campground, simply plug the line into the outlet and into the shore line receptacle in the service center. The 120VAC system automatically detects the presence of the shore power and acts to utilize it. There are no switches or breakers to bother with.

WARNING: Never substitute any other cord for the line provided. Do not use the line if there is any sign of damage to the line or the receptacle. If the line must be replaced, replace it with a line of at least the same rating.

INVERTER

The inverter transforms 12VDC power into 120VAC usable by the major appliances. The inverter allows the use of these circuits without the generator or shore line, using just the power stored in the house batteries. Not all circuits are connected to the inverter, and thus not all appliances can be run without a 120VAC power source - generator or shore line.

The inverter has its own internal breakers, and thus power from the inverter is not channeled through the circuit breaker panel. If power is not reaching appliances served by the inverter, you probably must reset the inverter by pressing the reset button fully.

The power for the inverter comes from the house batteries, and you should keep an eye on the battery level as you use your appliances. The battery level can be checked using the monitor panel in the kitchen.

Your coach is equipped with either a 1000W inverter or 2000W inverter. The 1000W inverter is ample for most purposes. However, the it is not capable of safely powering the microwave oven. If your coach has the 2000W model, the microwave can be run off of the inverter circuit. Otherwise, the microwave oven requires either a shore-line or the generator to operate.

12VDC SYSTEM

The 12VDC system provides power for a variety of applications. Many of the lights use 12VDC, as do the fans, the water pump, leveler pump, and of course, the chassis accessories. In addition, 12VDC power is used to start the generator, ignite the furnace and power its fans, and run the indicator lights in the refrigerator and monitor panel. And through the inverter the 12VDC system also can provide power for the 120VAC appliances.

The 12VDC system is divided into two sections. The "chassis" section powers the engine, running lights, dash accessories, and levelers. It includes the "chassis" battery and alternator.

The "house" section powers the 12VDC interior lighting, ceiling fans, generator, refrigerator, furnace, water heater, monitor panel, and water pump. It includes the set of "house" batteries, and also powers the inverter.

The two systems are connected by an isolator and boost switch, which allows the house system to supplement the chassis system, while simultaneously preventing the chassis battery from being drained by house demands. This is more fully discussed in the next section.

CHASSIS SYSTEM, ISOLATOR, AND BOOST

The chassis' electrical system is enhanced by Safari in several ways. The system provides power for starting the engine, and also powers the leveler pump. It is recharged by the alternator and a solar cell.

The solar cell provides a small trickle of power during the daytime to charge the chassis battery. This helps to maintain the battery charge even when parked for extended periods.

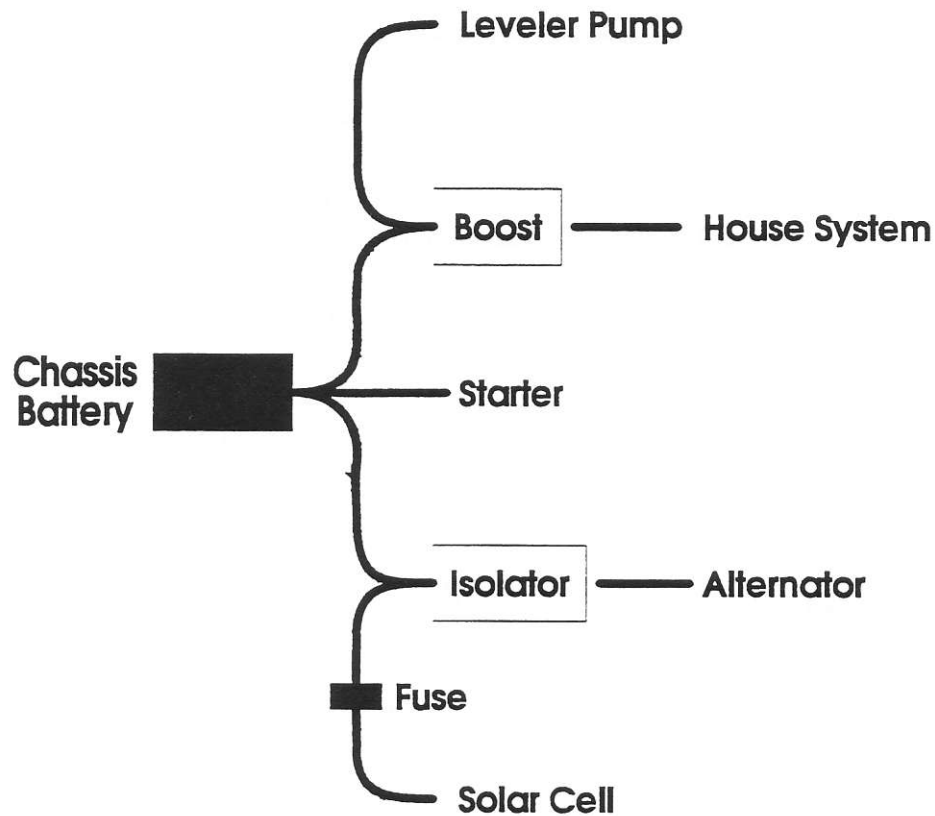

Chassis 12VDC System

Although all solar cells produce a drain when in the dark, for this cell that drain is virtually unmeasurable.

Power from the alternator is channeled through an isolator. This device allows the alternator to simultaneously charge the chassis and house system, while keeping the two systems separate. With the isolator, draining the house batteries will not affect the chassis battery, and vice-versa. With a modicum of care, at least one battery system will always be charged.

Should the chassis battery lose its charge and become unable to start the engine, it is possible to apply the house system to the task. A boost switch connects the two systems. By activating the switch, the starter can get power from the house batteries and converter.

ELECTRICAL SYSTEM

Since the house system can draw from the converter when 120VAC power is available, you can start your engine even if all the batteries are drained. The converter supplies 12VDC power from a 120VAC source, either the shore line or generator. (Of course, starting the generator also requires the house batteries, but is easier to start than the chassis engine.)

The boost switch should only be activated for the time that

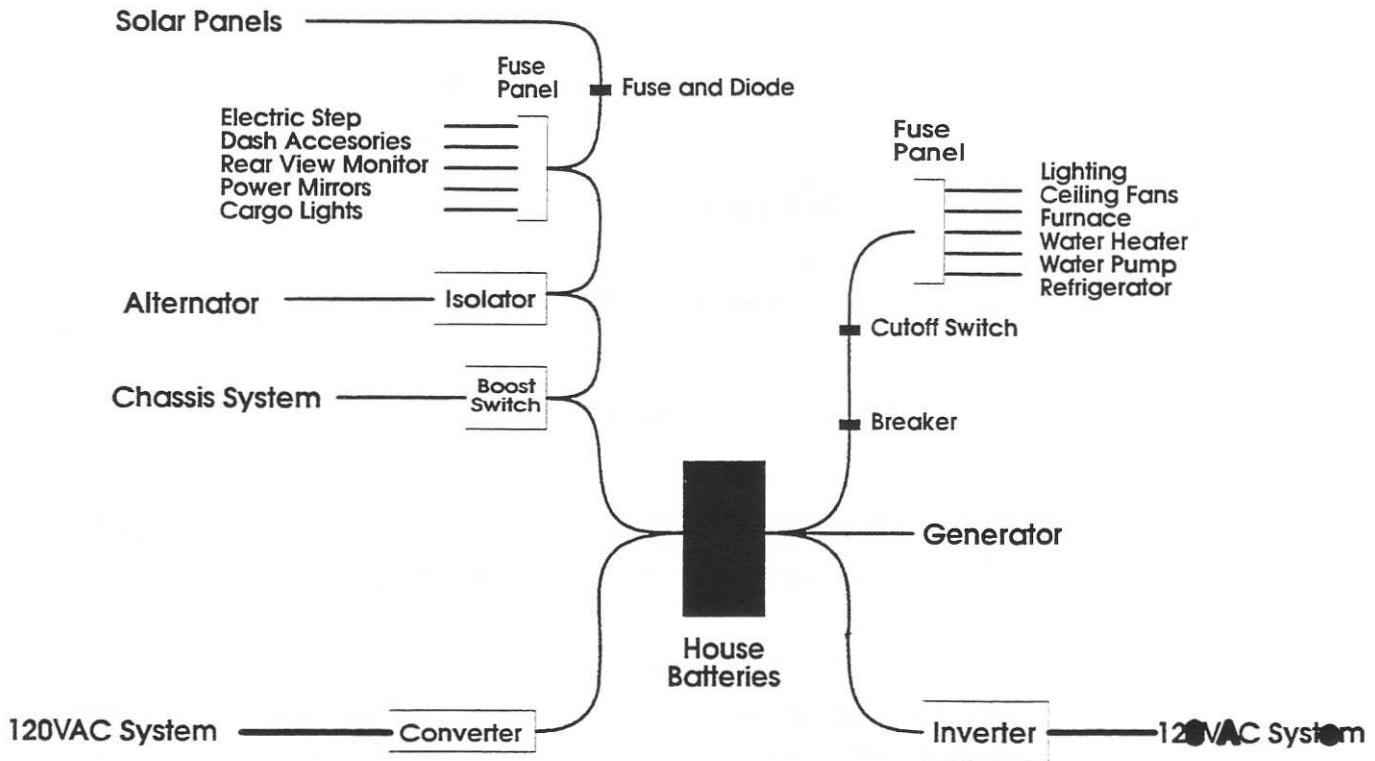

House 12VDC System

the power is needed. Leaving the switch activated allows the chassis battery to drain along with the house batteries while

you are using the 12VDC accessories and appliances. This could cause you extreme inconvenience.

HOUSE SYSTEM

The house 12VDC system provides the power for all 12VDC accessories and appliances, with the exception of the engine starter, leveler pump, and automotive functions. The system includes four batteries, designed to maintain their power even after repeated deep cycles. The system includes two fuse panels, one for interior and ceiling appliances, and the other for exterior and chassis based items.

The system is charged by several sources. The alternator charges the system through the isolator. As mentioned above, the isolator keeps the house system separate from the chassis system, preventing the chassis battery from being drained by the house appliances. The converter provides power from a 120VAC source, either the generator or a shore line. It operates automatically according to the presence of 120VAC power. The large solar panels also work to charge the house batteries. A blocking diode prevents the panels from drawing on the batteries in the dark.

The house battery system provides power directly to the inverter and generator starter. It also is hooked to the chassis system through the boost switch. These devices are all connected directly to the house batteries, with no intervening breakers or switches.

The remaining 12VDC appliances are served through two fuse panels. One panel sits on the front firewall and serves circuits which run through the chassis. These include the electric step, dash accessories, rear monitor, mirrors, and cargo bay lights. This fuse panel is connected directly to the house batteries, with no intervening breaker or switch.

The second panel is located by the 120VAC breaker center. It serves circuits which run through the roof to the interior appliances and lighting. These include the ceiling fans, furnace, water heater, water pump, and refrigerator. This panel is separated from the batteries by a breaker and a cutoff switch. The breaker is located near the battery tray. The cutoff switch is mounted in the stairwell. When storing the coach you should use the cutoff switch to prevent the appliances and lights from draining the batteries in your absence.

The strength of the batteries can be checked using the monitor panel in the kitchen. The monitor can only give a general indication of the charge level of the battery, but is an important tool for your power management.

With four ways to recharge your batteries (shore line, generator, alternator, solar cells), you have plenty of options to assist your power management. One factor to remember is that recharging time is greatly affected by the load. The less drain from lighting and accessories, the faster the batteries will recover.

When using the amplified TV antenna, don't forget to turn it off when it's not in use. It will continue to draw power even when the television is off. Look for the red "on" light on the face of the antenna switch plate located in the overhead cabinet.

FUSES

Fuses offer a simple and effective method of protecting the 12VDC lines from overloads. By burning out during an overload, they stop the current and end the hazard the overloaded circuit might present to the appliances and to the coach. Fuses are an important safety feature, and should never be bypassed.

If power no longer flows to a particular 12VDC appliance or circuit, the fuse should be one of the first items to check. A fuse can be checked visually, and if you are in doubt, an ohmmeter will detect whether the fuse still conducts electricity. If the fuse is blown then there may be a problem in the system. Check the appliances on the circuit for signs of damage or defects and check the wiring for possible shorts. When replacing the fuse, always use a fuse of the same amperage rating - never higher.

CHAPTER TWO

CHASSIS AND DASH

Your Safari motor home is built on a Magnum chassis. The chassis manufacturer provides a thorough manual which is included in your warranty package. This manual will outline the enhancements Safari has provided, and underscore important topics from the chassis manufacturer's manual. It is not a replacement for the chassis operator manual. Read the manual provided by the chassis manufacturer, and keep it handy for reference and for service information.

WARNING: Be familiar with all procedures, cautions and warnings given in the chassis manufacturer Operator Manual before operating your motor home. The book you are now reading is only for quick reference.

INSTRUMENTS AND CONTROLS

The Safari dash is designed to be easy to read and easy to use. All important gauges are placed directly in front of the driver and are arranged for quick interpretation. The controls are arranged around the central instrument cluster, and are provided with icons for quick identification. Most of these items require little explanation, but they are summarized here.

WARNING: Watch your gauges closely while driving. If any readings are not in their normal operating range, take appropriate action immediately.

INSTRUMENTS AND CONTROLS

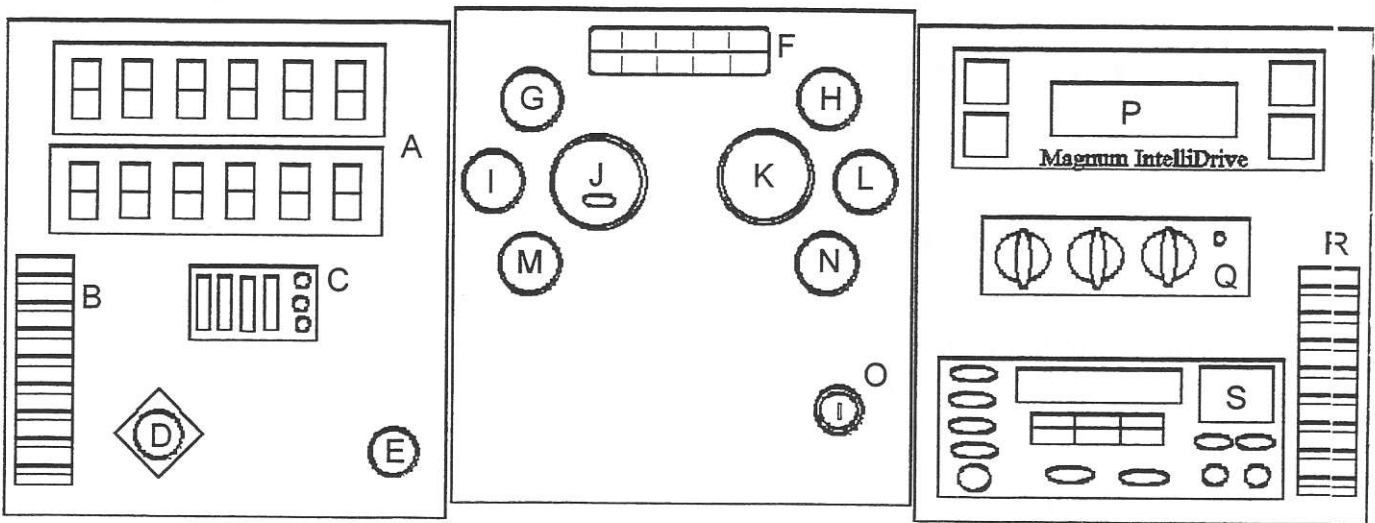

MAIN DASH

- | | |
|---------------------------------------|-------------------------------|
| A. Switch Banks | M. Turbo Gauge |
| B. Vent | N. Battery Voltage |
| C. Hydraulic Leveling System Controls | O. Ignition Switch |
| D. Parking Brake | P. Magnum IntelliDrive System |
| E. Light Knob | Q. A/C and Heat Controls |
| F. Indicator Lights | R. Vent |
| G. Coolant Temperature Gauge | S. Stereo System |
| H. Fuel Gauge | |
| I. Oil Pressure | |
| J. Speedometer and Odometer | |
| K. Tachometer | |
| L. Transmission Temperature | |

A. - Switch Banks

Please refer to the Switch Bank section at the end of this chapter.

B. - Vent

For air conditioning and heating.

C. - Hydraulic Leveling System Controls

Please refer to the operating instructions in the RCA manual or for a quick reference see your Safari Owners Manual.

D. - Parking Brake

To set the parking brake, hold the service brake down and pull out the park brake control. Once the park brake is out, the service brake may be released when the engine is in neutral. To release the park brake, hold the service brake down and push the park brake control valve back in. Do not attempt to drive with the parking brake set.

E. - Light Knob

To turn the parking lights on pull the knob part of the way out. To turn the headlights on pull the knob all of the way out.

F. - Warning Lights

A variety of warning lights will activate under certain conditions to warn you of potential problems. Some of these warnings read as follows; check engine, fast idle, park brake, do not shift, inlet air heater, and brake service.

G. - Coolant Temperature

The normal operating temperature for the engine is 190 to 215 degrees Fahrenheit. Overheating can occur because of insufficient coolant or a problem in the cooling system. It can also occur in hot weather with slow or stop-and-go driving. If the temperature reading exceeds this level, pull over promptly and allow the engine to cool. At a maximum, under severe conditions you may operate the engine up to 230 degrees for brief periods of time. However, extended or frequent operation at this temperature will void your engine warranty.

H. - Fuel

The fuel reading will fluctuate when cornering, accelerating, braking, and climbing or descending hills. The fuel tank holds 90-105 gallons, depending on the model.

INSTRUMENTS AND CONTROLS

I. - Oil Pressure

This indicates the proper functioning of the engine lubrication. With the engine idling this should read about 10 PSI, and while driving it should rise to about 35 PSI. If the pressure drops significantly below this level, stop the engine and check the oil level. When cold, the pressure will be considerably higher due to the increased viscosity of the oil.

J. - Speedometer w/ Odometer

The speedometer indicates the forward speed of the vehicle. The odometer indicates the total distance that the vehicle has traveled.

K. - Tachometer

The tachometer reads the engine rpm (revolutions per minute). The reading must be multiplied by 100. The engine should not be run at less than 1000 rpm for extended periods of time.

L. - Transmission Temperature

This normally should be between 140 and 250 degrees Fahrenheit. If it reaches 290 degrees, stop the vehicle, shift into neutral, and run the engine at 1200 rpm for two minutes or more. The temperature should drop to its normal range. If problems persist, check the transmission oil level.

M. - Turbo Gauge

The turbo boost gauge shows the relative boost of pressure in the turbo. Normal boost at a full load for a 250 horsepower engine is 25psi and normal for a 300 horsepower engine is 27 psi.

N. - DC Voltmeter

This indicates the proper functioning of the chassis DC system - particularly the batteries and alternator. With the engine off and the key switch on it should read approximately 12 volts. With the engine running, it should be approximately 14 volts.

O. - Ignition Switch

P. - Magnum IntelliDrive System

For instructions on operating the Magnum IntelliDrive System, please refer to the guide in your owners packet.

Q.- A/C and Heat Control

Please refer to operating instructions included in your owners manual.

R. - Vent

For air conditioning and heating.

S. - Stereo

See the stereo manual for instructions on how to operate the stereo system.

INSTRUMENTS AND CONTROLS

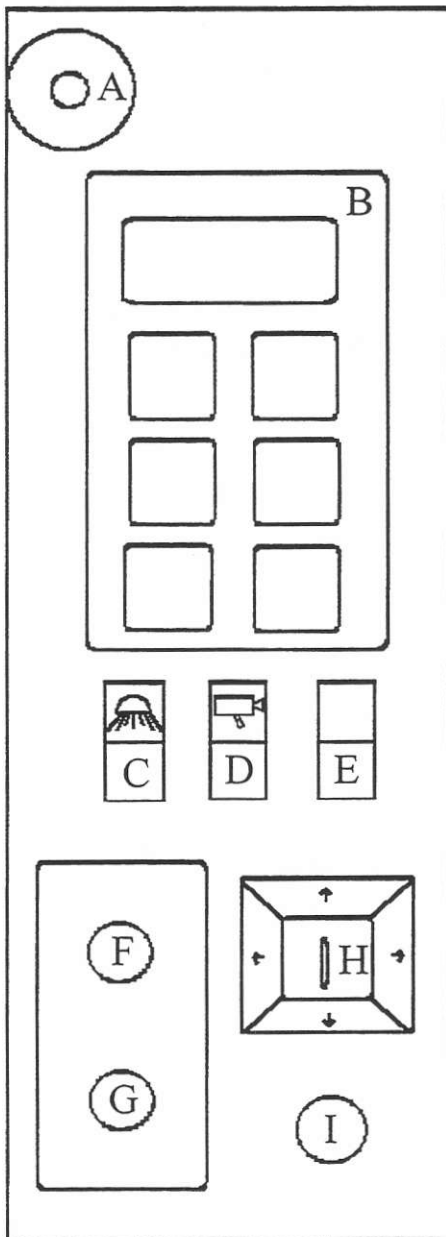

SIDE CONTROL PANEL

- A. Level
- B. Transmission
- C. Clearance Lights
- D. Back-up Camera
- E. Exhaust Brake
- F. Cruise Control On/Off Switch
- G. Cruise Control Set/Resume Switch
- H. Mirror Controls
- I. Fast Idle

A. - Level

The level is placed here to help in leveling the coach with the hydraulic system.

B. - Transmission

The transmission panel instructions are explained thoroughly in the Allison World Transmission manual. The buttons on the panel include reverse, mode, neutral, drive, shift up, and shift down.

C. - Light

The light switch turns on the Clearance lights.

D. - Back-up Camera

The camera switch will turn on the rear camera so that it can be viewed on the TV monitor.

E. - Exhaust Brake

The Exhaust Brake switch brake should be used in order to increase stopping efficiency and save the primary brakes from overuse.

F. and G. - Cruise Control On/Off Switch and Set/Resume Switch

The cruise control on and off switch and the cruise control set and resume switch are to be used in operating the coaches cruise control. Please refer to your Cat 3126 Operation's and Maintenance manual for full instructions on how to use the cruise control.

H. - Mirror Controls

One control operates both mirrors. The switch in the center of the square determines which mirror is being adjusted.

I. - Fast Idle

The fast idle enable switch, is enabled by depressing the switch and then releasing it. This ramps the engine up to the programmed fast idle of 1000 rpm. See your chassis manufacturers manual for further information about the fast idle switch.

SWITCH BANKS

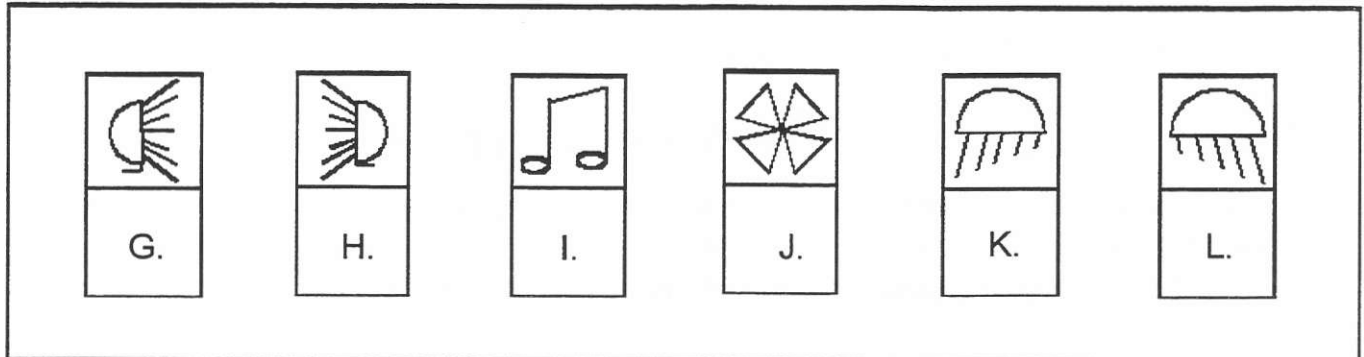
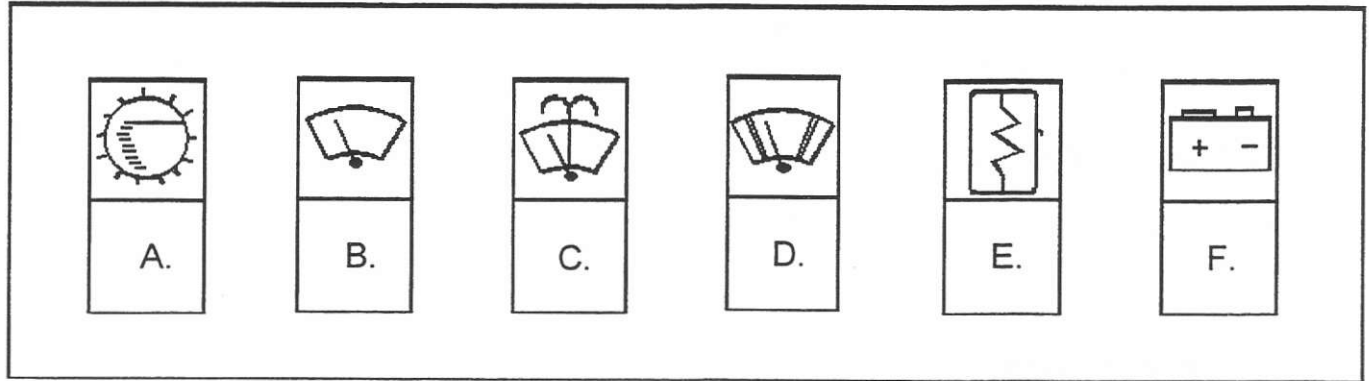

SWITCH BANKS

A. - Dash Lights

B. - Windshield Wipers

C. - Windshield Washer

D. - Intermittent Windshield Washer

E. - Mirror Heaters

F. - Battery Boost

G. -Front Driving Lights

H. - Rear Driving Lights

I. - Dash AM/FM Radio

J. - Cab Fans

K. - Left Docking Lights

L. - Right Docking Lights

OTHER CONTROLS AND ACCESSORIES

On the lower dash there are two major items. To the right is the dash heating and air conditioning control. The dash heating and A/C is intended to provide a comfortable environment in the front cab area. By utilizing the engine power and heat, it reduces the load on the main appliances. It is a supplement to, not a replacement of the main climate systems.

On the steering column the following items are located: turn signals and headlight dimmer, horn, tilt and telescoping levers, and hazard flashers. The operation of these controls is detailed in the chassis manual.

OPERATION

Full instructions for the operation of the engine are given in the chassis manual. Read the manual and familiarize yourself with the procedures it details. This section is intended only to give an overview, and is not a replacement of the chassis manufacturer's book.

When starting the engine, first make sure the parking brake is on and the headlights are off. While starting you will want to minimize the load on the chassis batteries. Put the transmission in neutral and turn the key. Do not crank the starter for more than thirty seconds at a time. If the engine fails to start, wait before cranking again.

Check the engine oil pressure soon after starting. You should let the engine idle for three to five minutes before moving out, but do not idle the engine too long. Idling for more than about ten minutes can cause the fuel to not burn completely, which can cause various problems.

In cold weather the engine may be more difficult to start. Oil becomes thicker, making the engine crank more slowly. If you plan on traveling in cold areas (consistently below 20 degrees Fahrenheit), use a 5W20 or 5W30 CC/CE oil, rather than the 15W40 CE/SG recommended for moderate climates.

If the chassis batteries fail to provide enough power to crank the engine fast enough, you can press the boost switch and add the house batteries to add more power.

While running the engine, keep an eye on all the gauges provided. The normal operating ranges are given in the chassis manual.

Before shutting the engine down, allow it to idle for a few minutes to cool the combustion chamber, bearings, and shaft.

OTHER CONTROLS AND ACCESSORIES

FUEL

The engine is designed to run on Grade 2 or 2-D climatized diesel fuel. Diesel fuel is rated by a "cetane" number. This should be no less than 40, and in cold climates or high elevations should be 45 or higher.

Water in the fuel is removed by a separator located near the engine. This should be checked regularly, and drained when necessary. A clear bowl allows you to see how much water has been collected. A small knob on the bottom allows you to drain the water until the bowl contains pure fuel. The separator also contains a filter which should be changed regularly.

WORLD TRANSMISSION

The Allison World Transmission in your coach is a highly sophisticated electronically controlled automatic transmission. It's operated by a push-button panel to the left of the driver's seat. Despite it's unconventional shifter, it operates much like a standard automatic transmission. However, unlike a standard transmission, this unit contains sophisticated electronics which evaluate every situation and actually "learns" the most efficient shifting pattern to match your driving.

All that is necessary for normal driving is to press the button for the mode you wish the transmission to be in. Pressing the "N" puts it in neutral, "R" in reverse, and "D" in drive. The transmission will not shift into reverse if the coach is still moving forward. The arrows allow you to upshift or downshift while in drive. The transmission automatically prevents shifts that might be damaging to the transmission.

The panel contains status lights to indicate the presence of a problem. If any of these lights are displayed, consult the chassis manual immediately. The safeguards in the system may prevent certain shifts from occurring, and it will attempt to protect the transmission from further damage or problems. For further cruise control instructions consult your Allison World Transmission Manual.

MAINTENANCE

A full service schedule is included in the chassis manual. This guide should be kept with the coach and referred to regularly. The schedule includes an inspection regimen which should be followed every day of travel, and another regimen to follow every 5000 miles.

The daily regimen includes the following:

Check fuel/water separator.

Check coolant level.

Check transmission fluid level.

Check engine oil level.

Check tires for pressure and unusual damage

The following routine should be performed at least every week:

Check belts for proper tension

Check power steering fluid.

Check engine fan.

Check batteries.

Check brake master cylinder fluid level.

The following routine should be performed at least every 5000 miles:

Check air intake system for damage.

Check steering box for leakage.

Check hydraulic fluid reservoir level, and inspect lines.

Check lug nut torque.

Check air filter minder. If red, replace air cleaner.

Check rear axle lubricant level.

OTHER CONTROLS AND ACCESSORIES

Lubricate front axle king pins, steering linkage, drive shaft, U-joints, and slip yoke.

Other service regimens are to be followed at 10,000, 15,000, 20,000, and 25,000 mile intervals. Please refer to your chassis manual.

COOLANT

Your coach has a coolant expansion tank mounted above the engine. It is through this tank that you should check the coolant level and add more liquid if necessary. A sight glass on the tank lets you determine whether the level is sufficient without opening the tank. If no liquid appears in the window, then you should add coolant.

To add coolant, first open both bleeder valves on the tank. The engine must be off. Then open the tank and add the coolant to nearly fill the tank. Replace the cap on the tank, then close the bleeder valves.

WARNING: Do not add coolant through the fill on the radiator. Always add it through the expansion tank above the engine.

TIRE SERVICE

The tires on your chassis are not intended to be changed except by a tire dealer with the appropriate equipment. Do not allow the tires to be serviced by anyone but a qualified professional. The lug nuts are tightened to over 450 ft-lbs of torque, which is far more than any standard torque wrench provides.

After a tire has been installed, have the lug torque checked after about fifty miles and again after 500 miles.

WARNING: Do not attempt to change a tire without the special equipment required.

CHAPTER THREE

REFERENCE

This chapter provides charts and tables giving reference information. This information was correct at the time of printing, but is subject to change without notice. The presence of certain options may also cause changes affecting these tables.

LOCATOR GUIDE

The following table is designed to help you locate various items in your coach. The location of many items varies with the floor plan and with certain options.

In the table the following abbreviations are used: DS - Driver's Side; PS - Passenger's Side.

Appliances and Connections

| | | |
|------------------------|-----|---------------------------------|
| House Service Center | All | DS, Forward of Rear Wheels |
| Chassis Service Center | All | PS, Behind Rear Wheels |
| LP Gas Tank | All | Behind Front Wheels |
| Furnace | All | Under Refrigerator /Under Couch |
| Generator | All | DS, Behind Rear Wheels |

LOCATOR GUIDE

Plumbing and Waste

| | | |
|-----------------------|-----|------------------------------|
| Fresh Water Tank | All | Basement Front Between Rails |
| Black Waste Tank | All | Under Toilet, Between Rails |
| Grey Waste Tank | All | Under Floor, Between Rails |
| Tank Drain Valve | All | Fresh Water Tank Rear |
| Low Point Drain Valve | All | House Service Center |
| Water Pump | All | DS In Front Of Back Wheel |
| Water Heater | All | Under Lazy Susan |

Electrical

| | | |
|--------------------------------|-----|--------------------------|
| Inverter / Charger | All | DS, Behind Rear Wheels |
| Transfer Switch | All | DS, Behind Rear Wheels |
| House Batteries | All | PS, Behind Rear Wheels |
| Chassis Batteries | All | PS, Behind Rear Wheels |
| 12V Cutoff Switch | All | Step Well |
| Inverter Monitor | All | Bedroom Overhead Cabinet |
| Inverter Outlet | All | Kitchen |
| AC Breaker Panel | All | Bedroom Overhead Cabinet |
| Fuse Panel - House | All | Bedroom Overhead Cabinet |
| Fuse Panels - Chassis and Dash | All | DS Front Hood Access |
| Isolator | All | Bed Box |

Engine and Chassis

| | | |
|--------------------------------|-----|------------------------------------|
| Fuel Tank | All | Between Rails, Behind Front Axle |
| Fuel Fill | All | DS, Front Corner |
| Oil Fill | All | Above Radiator at Rear Access |
| Oil Dipstick | All | Chassis Service Center |
| Transmission Fill and Dipstick | All | Chassis Service Center |
| Hydraulic Fluid Reservoir | All | Chassis Service Center |
| Fuel/Water Separator | All | Chassis Service Center |
| Coolant Fill | All | Above Radiator |
| Oil Filter | All | DS, Middle of Engine |
| Coolant Filter | All | DS, Top of Engine |
| Air Filter | All | PS Engine, Best reached from Below |
| Air Restriction Indicator | All | Chassis Service Center |
| Remote Engine Start | All | Chassis Service Center |
| Secondary Fuel Filter | All | Chassis Service Center |

Miscellaneous

| | | |
|------------------------------|-----|---|
| Monitor Panel | All | Above Entry / End Micro Cab |
| Water Pump Switch | All | Above Entry / End Micro Cab |
| Furnace/Front A/C Thermostat | All | Above Sofa , On Bedroom Wall Above Ice Maker |
| Generator Switch | All | Above Entry / End Micro Cab |
| Electric Step Switch | All | Above Entry |
| Antenna Boost Switch | All | PS Front Overhead Cabinet |

FUSES

The following tables list the purposes and requirements of the various fuses. These are subject to change without notice. Fuse Blocks 1,2, and 3 are located on the front fire-wall, accessible through the left hood access. The House Fuse Block and the AC Breakers are located in the bedroom overhead cabinet.

FUSES

Fuse Block 1

This block is connected to the chassis battery, and is "hot" when the ignition key is on.

| | | |
|---|--------|--|
| 1 | 25 Amp | Fan Relay |
| 2 | 15 | Cruise Control Light |
| 3 | 15 | Dash Gauges, Back-up Lights, CD Player, "CAT" Reader |
| 4 | 10 | Leveler Controls |
| 5 | 30 | Dash A/C Slow-Speed Fan |
| 6 | 10 | Pac Brake |
| 7 | 20 | Windshield Wipers |
| 8 | 5 | Windshield Wiper Washer, Remote Mirror Switch Light |
| 9 | 15 | Air Horn Pump, Entry Step Controls |

Fuse Block 2

This set of circuits runs off the chassis battery, but is always "hot". These items work regardless of whether the ignition is on.

| | | |
|----|--------|--|
| 10 | 15 Amp | Parking, Clearance, Marker, and A/C Panel Light, Delco Lights, Shifter, Cat ID |
| 11 | 20 | Emergency Flasher |
| 12 | 15 | Air Horn Relay/Pump |
| 13 | 10 | AM/FM Radio and CD Player (memory) |
| 14 | 10 | Cab Map Lights |
| 15 | 10 | Dash Switch Lights |
| 16 | 5 | Chassis Solar Panel |
| 17 | 5 | CB Radio, Stereo Clock |
| 18 | 10 | Gauge Lights, Headlight Relay |

Fuse Block 3

This set of circuits operates directly off of the house batteries. These circuits are "hot" regardless of the ignition key.

| | | |
|----|-------|------------------------|
| 19 | 5 Amp | Battery Boost Solenoid |
| 20 | 15 | Cargo Bay Lights |
| 21 | 30 | Entry Step |
| 22 | 5 | Rear Camera |
| 23 | 5 | Dash Fans |
| 24 | 10 | Mirror Heaters |
| 25 | 25 | Fog Lights |
| 26 | 15 | Cigarette Lighter |
| 27 | 20 | Docking Lights |

House Fuse Block

This set of circuits operates off of the house batteries. These circuits can be cut off using the 12VDC Cutoff Switch in the step well. Note that the CO detector is also connected through this switch. If the cutoff switch is off, the CO detector will not function.

| | | |
|---|--------|--------------------------|
| 1 | 20 Amp | Living Room Lights |
| 2 | 20 | Kitchen Lights |
| 3 | 20 | Bedroom/Bath Lights |
| 4 | 10 | Power Vents |
| 5 | 15 | Water Pump |
| 6 | 10 | Water Heater |
| 7 | 15 | Furnace, A/C Thermostats |
| 8 | 15 | TV Antenna Boost |
| 9 | 5 | Refrigerator |